

# Superposition

Christian Wüthrich

<http://philosophy.ucsd.edu/faculty/wuthrich/>

**146 Philosophy of Physics: Quantum Mechanics**  
Winter 2009

# Setting things up

Albert, *Quantum Mechanics and Experience*, Ch. 1

- electrons with two properties: “color” (black, white), “hardness” (soft, hard)
- **color box**: measuring device with three apertures such that incoming  $e^-$  are sorted according to their color
- **hardness box**: similar device sorting  $e^-$  into hard and soft ones
- measurements **repeatable**: if after measurement,  $e^-$  is fed into same type of box w/out tampering, then same measurement outcome will be observed
- Q: Are properties related, i.e. are there correlations bw values of hardness and color of  $e^-$ ?
- ⇒ combine boxes to measure correlations
- precisely half of  $e^-$  coming out of one aperture of first box come out of each aperture of second box
- ⇒ no correlations, color (hardness) of  $e^-$  entails nothing about its hardness (color)

# Three-box experiments

- suppose we have three boxes alined for subsequent measurement, s.t. the first and third box are of same type as one another, but of different type from second box
  - no tampering with  $e^-$  bw boxes
  - $e^-$  going into third box is presumably known to have a particular pair of color and hardness properties (e.g. white and soft)
- ⇒ it seems as if we can predict the outcome of the third measurement
- It turns out that we can't: precisely half of the  $e^-$  will come out of each aperture of third box.
  - Apparently, presence of middle box itself constitutes some sort of tampering: middle box seems responsible for changing half of  $e^-$  since we know that two identical boxes in sequence show a different behaviour.

- Can boxes be built less crudely, can intermediate measurements be refined such as to avoid this? No, we can't even "move the statistics of [...] of disruption even so much as one millionth of one percentage point away from fifty-fifty" (5f), i.e. every device that qualifies as e.g. hardness box will randomize color.
- What is it that determines precisely **which**  $e^-$  have their properties changed by second box and which don't? Let's look for correlations bw measurable properties of incoming  $e^-$  and their final measurement outcome. But there is absolutely no such correlation...  $\Rightarrow$  this Q has no answer

# Color-and-hardness boxes

- boxes w/ five apertures, incl. one for each pair of measurement outcomes
- box like that would have to consist of a color box and a hardness box
- ⇒ Problem: the second device will randomize  $e^-$  wrt to first measurement
- Albert: “So the task of putting ourselves in a position to say ‘the color of this electron is now such-and-such and the hardness of this electron is now such-and-such’ seems to be fundamentally beyond our means.” (7)
- ⇒ example of [uncertainty principle](#), since measurements of one of the two incompatible properties disrupts the measurement of the other

# Stern-Gerlach experiment

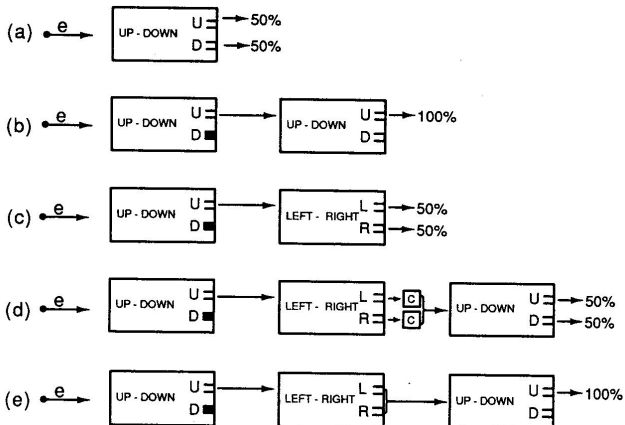

Figure: Stern-Gerlach experiment with “mixture” (d) and “superposition” (e) (Sklar, Fig. 4.4)

# Two-path experiments

- Consider a more complicated device as in figure 1.4 in Albert.
- Suppose that white  $e^-$  is fed into device and measure its hardness at  $h$  and  $s$ . Expectation: we find half hard and half soft  $e^-$ . And this is what we find.
- Suppose that hard  $e^-$  is fed into device and then measure its color at  $h$  and  $s$ . Expectation: find half of  $e^-$  to be white and half black. And this is what we find.
- Suppose we feed white  $e^-$  into device and measure their color at  $h$  and  $s$ . Expectation: half should be found to be white, half black. But this is not at all what we find: all  $e^-$  are found to be white!
- Add a sliding wall as in figure 1.5.
- What happens if we slide wall in?
- Expectation: overall output goes down 50%; given that all  $e^-$  were just found to be white, they should still be so, right?
- But they are not: only half of the  $e^-$  are now white, the other half black.

# Considering routes of electrons: superposition

Which route does an electron take when wall is out?

- Can it have taken  $h$ ? Apparently not, since these  $e^-$  are known to randomize color.
  - Can it have taken  $s$ ? No, same reason.
  - Can it somehow have taken *both* routes? Apparently not, since whenever we stop experiment and look to see where the  $e^-$  is, we find it either on  $h$  or on  $s$ .
  - Can it have taken *neither* route? No, since if we wall up both routes, nothing goes through.
- ⇒ Albert: “Electrons passing through this apparatus... do not take route  $h$  and do not take route  $s$  and do not take both of those routes and do not take neither of those routes; and the trouble is that those four possibilities are simply all of the logical possibilities that we have any notion to entertain... The name of that new mode (which is just a name for something we don’t understand) is *superposition*.” (11)

# Double-slit experiment

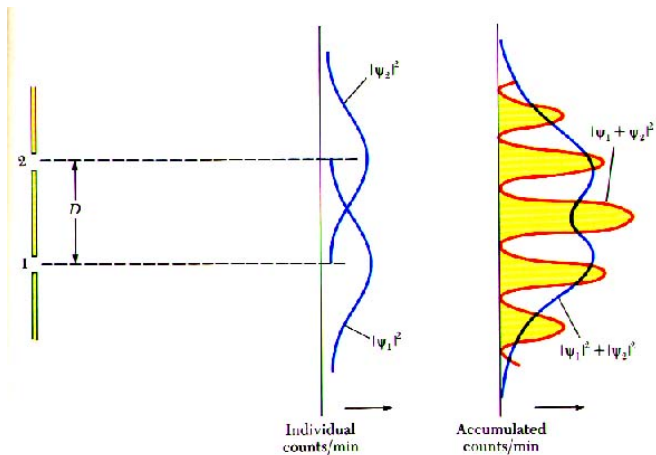

Figure: Interference pattern found in double-slit experiments.